

**SANYO**

**Cadnica**

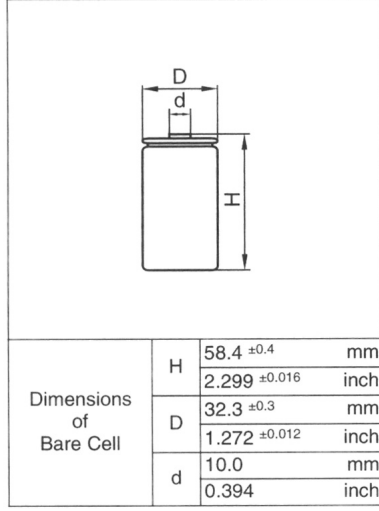
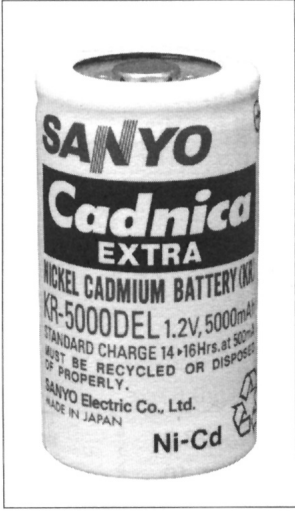

# Cell Type KR-5000DEL

## Specifications

Nominal Capacity		5000mAh	
Nominal Voltage		1.2V	
Charging Current	Standard	500mA	
	Fast	7500mA	
Charging Time	Standard	14 to 16Hrs.	
	Fast	about 1Hr.	
Ambient Temperature	Charge	Standard	0 to 45 °C [32 to 113 °F]
		Fast	0 to 45 °C [32 to 113 °F]
	Discharge		-20 to 60 °C [-4 to 140 °F]
	Storage		-30 to 50 °C [-22 to 122 °F]
Internal Impedance(Av.) (at 50% discharge)		3.5mOhms (at 1000Hz)	
Weight		150g/5.28oz	
Dimensions(D)x(H) (with tube)		33.0 <sup>0</sup> <sub>-1</sub> x 60 <sup>0</sup> <sub>-2</sub> mm 1.3 <sup>0</sup> <sub>-0.04</sub> x 2.36 <sup>0</sup> <sub>-0.08</sub> inch	

### Typical Characteristics

#### Charge

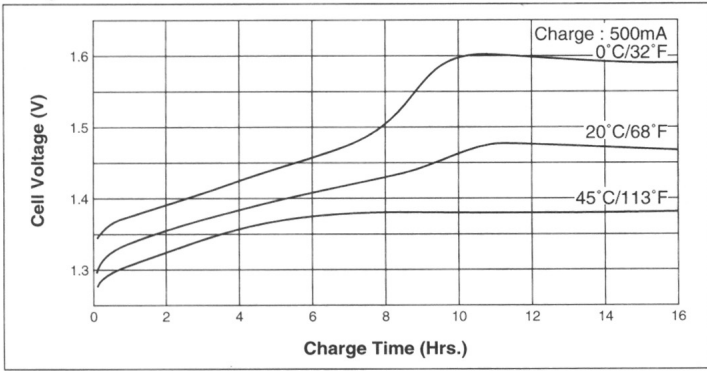

#### Discharge (at high rate)

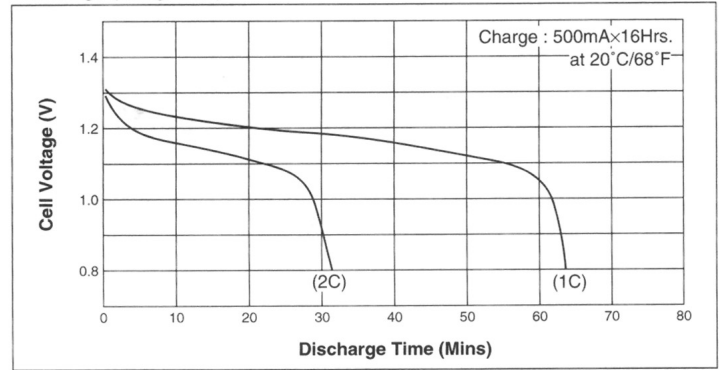

#### Charge

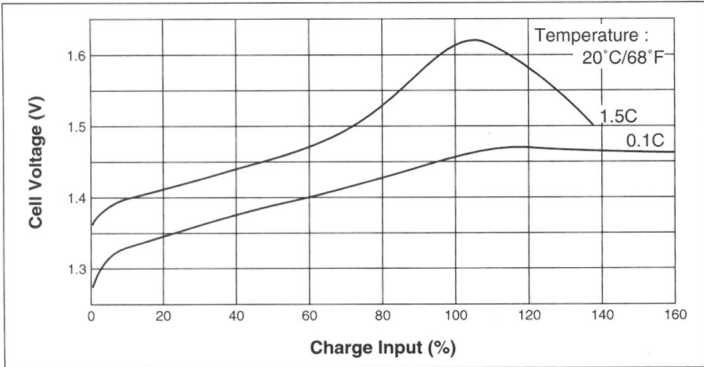

#### Discharge (at high rate)

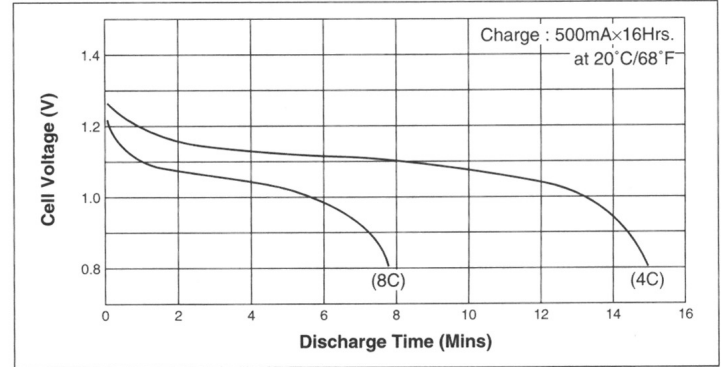

#### Discharge (at low rate)

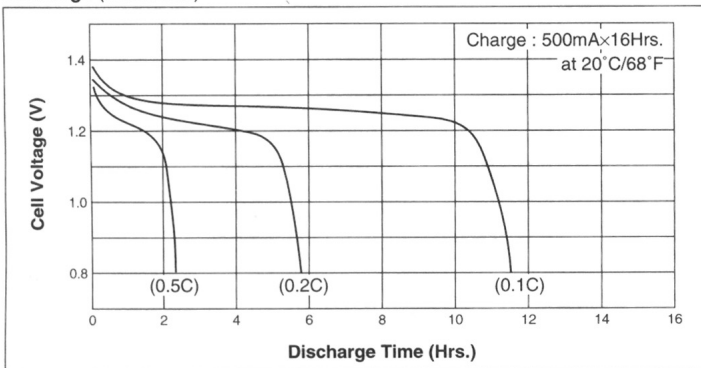

#### Temperature (Charge & Discharge)

